

Længde af RB-profil i h.t. beregninger, dog minimum H.

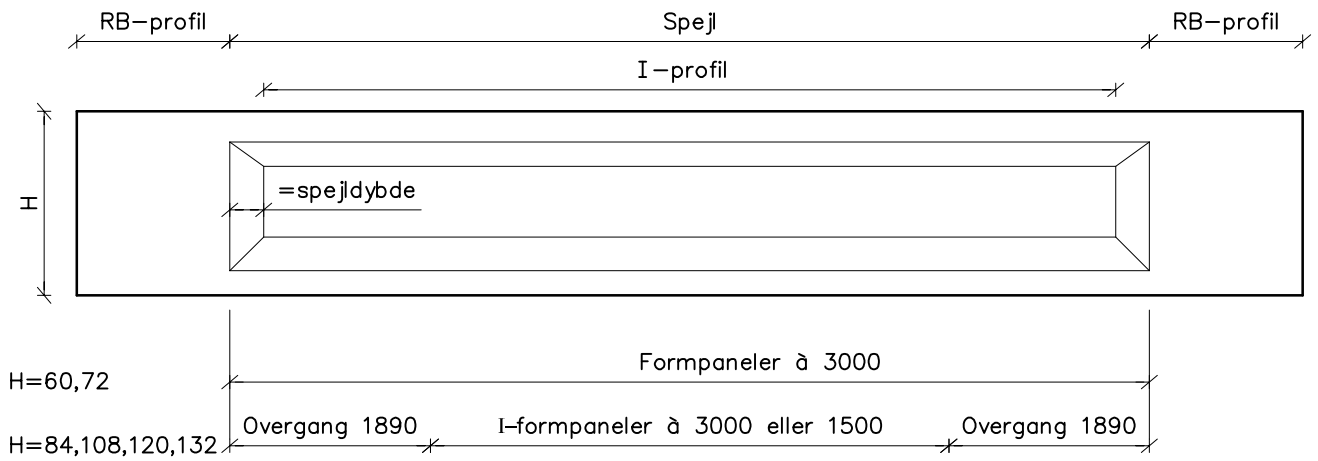

Længde på spejl

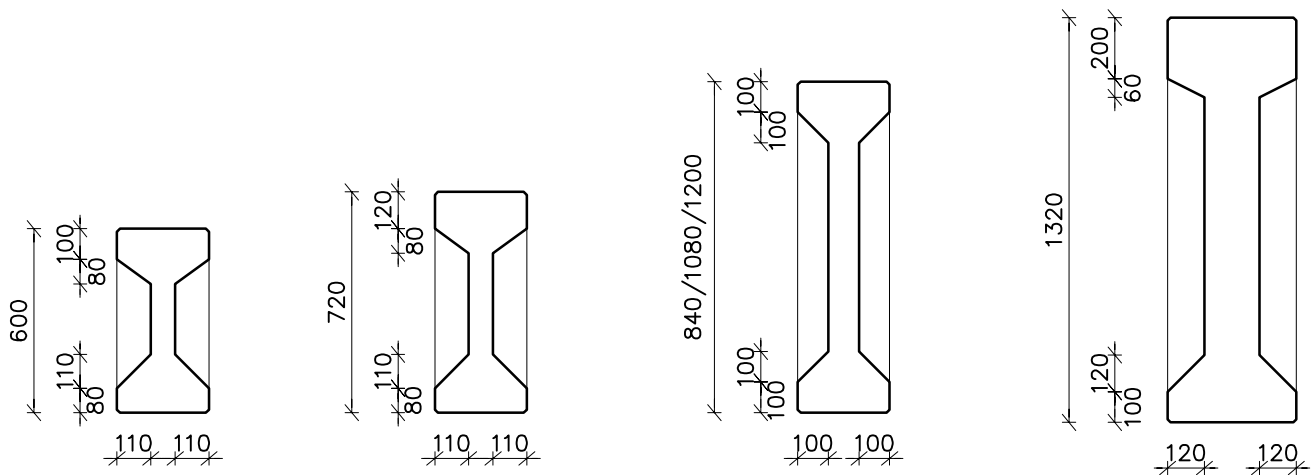

Snit med mål på I-profil

Standardtværsnit						
B=300	IB 30/60	IB 30/72	IB 30/84	IB 30/108	IB 30/120	
B=360	IB 36/60	IB 36/72	IB 36/84	IB 36/108	IB 36/120	IB 36/132
B=420						IB 42/132
	H=600	H=720	H=840	H=1080	H=1200	H=1320

pmc 26.05.15 Kl: 09.28 EXT_2010-01_IB.dwg

CONSOLIS SPÆNCOM STANDARD	IB Geometri					EXT
	Tegn.dato: 18.05.04 Tegn. JJ / Godk. LAR Rev. Dato D 30.01.15 Tegn. pmc / Godk. KN					2010
					1	